

Dante Working Knowledge

(Hands On)



Patrick Killianey



Senior Technical Training Manager
1200 NW Naito Parkway, Suite 630
Portland, OR 97209
patrick.killianey@audinate.com

Who is Audinate and What is Dante?

What is Dante



Headquartered in
Sydney, Australia

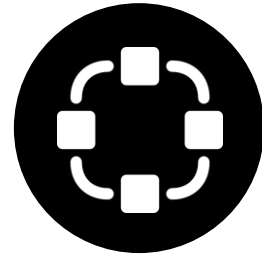

Network
Engineers First



Develop Dante as
100%
interoperable
solution for all
manufacturers.

As of July, 2019

What Audinate Makes

Dante Technology

(All of it.)

For the Manufacturer:

- ◆ Hardware Modules
- ◆ Firmware and Libraries

For the End Customer:

- ◆ Dante Controller
- ◆ Dante Virtual Soundcard
- ◆ Dante Via
- ◆ Dante Domain Manager

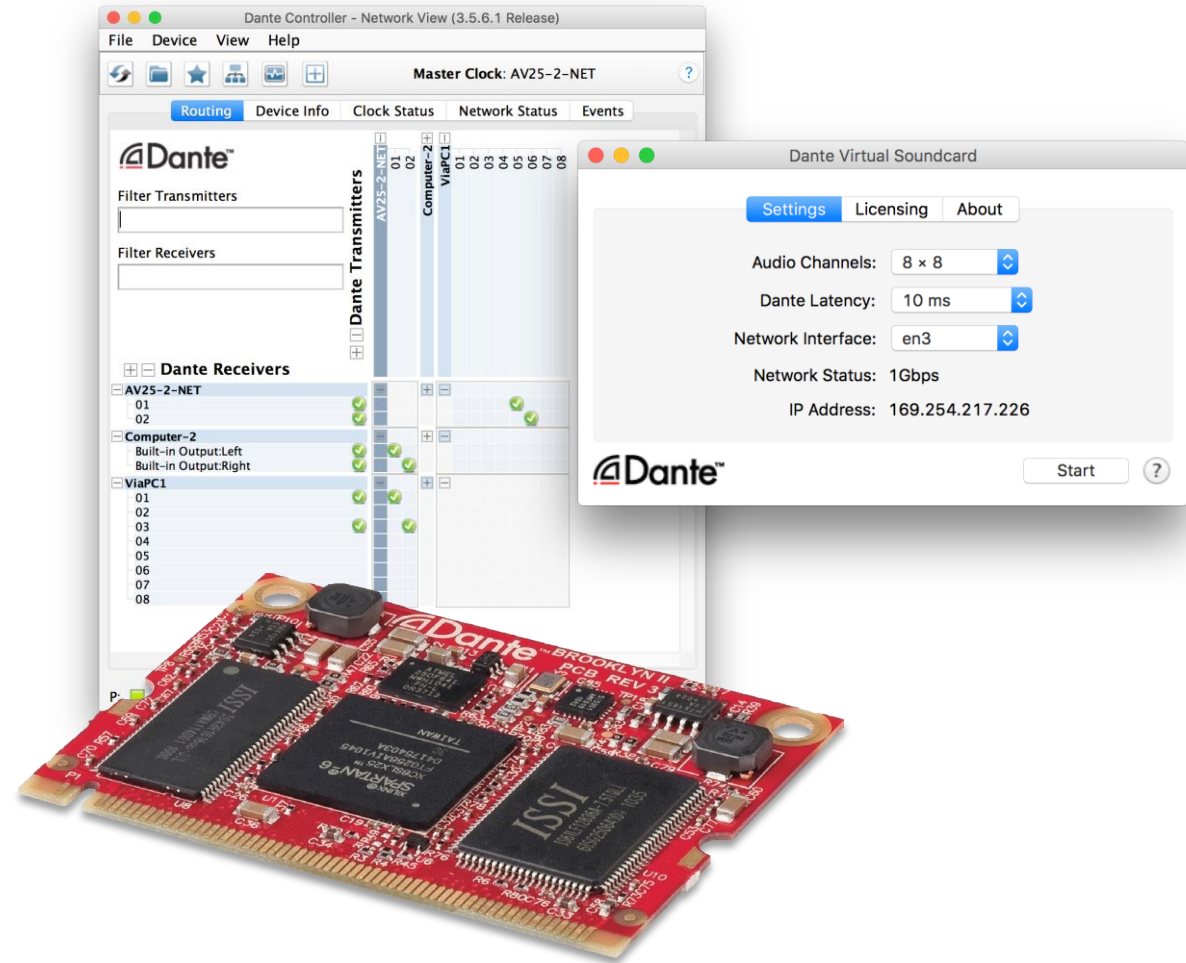

450+

Licensed
manufacturers
making
Dante-enabled
products

2,000+

Dante-enabled
products in the
market.

1,000,000+

Dante-enabled
products in the
field.

As of July, 2019

From Entry Level to Top-of-the-Line in Any Audio-Visual Market





100,000+

Dante Users

40,000+

Dante-Certified Individuals

Our technology's functionality is a given. We invest in people.

As of July, 2019

Why Is Professional Audio Using Networks?



Q: Why do we use Digital Audio?

... Is it just about Sound Quality?

Why Do We Use Digital Audio?



Instant Access, Polyphony/Multitimbral

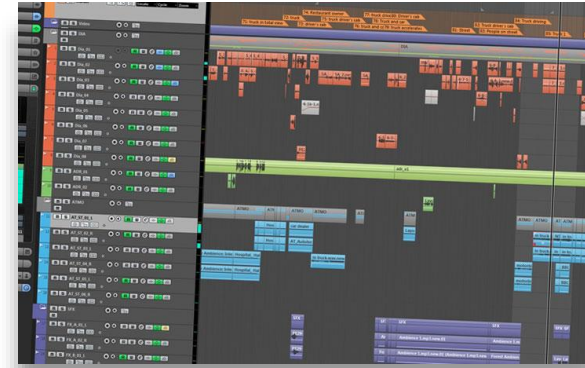

Non-Linear Editing, Virtual Tracks, Undo



Convenience/Portability



Recall, Scalability, Compact



Q: Why do we use Digital Audio?

A: It enables us to do things we couldn't do before.

Digital Snake ≠ Digital Audio Network

CAT5e Cable	✓	✓	CAT5e Cable
Digital Audio	✓	✓	Digital Audio
	✗	✓	Mac/PC Audio Integration
	✗	✓	Unlimited Signal Splitting
	✗	✓	Expandable Capacity
	✗	✓	Links Multiple Systems

“Point-to-Point” Wiring Means...

Whatever goes in here...

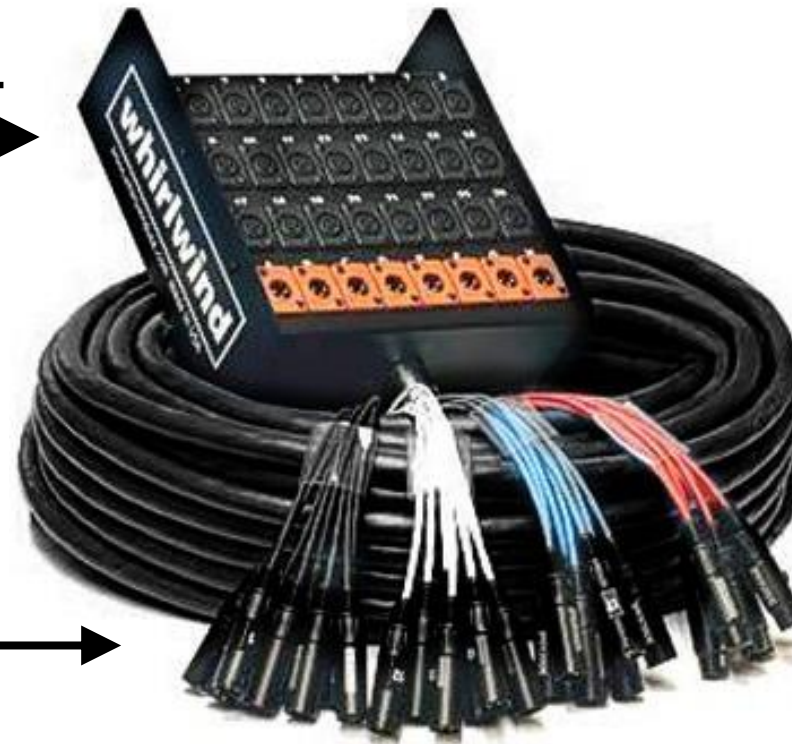

Comes out here.



Digital Audio Snakes vs Digital Audio Networks

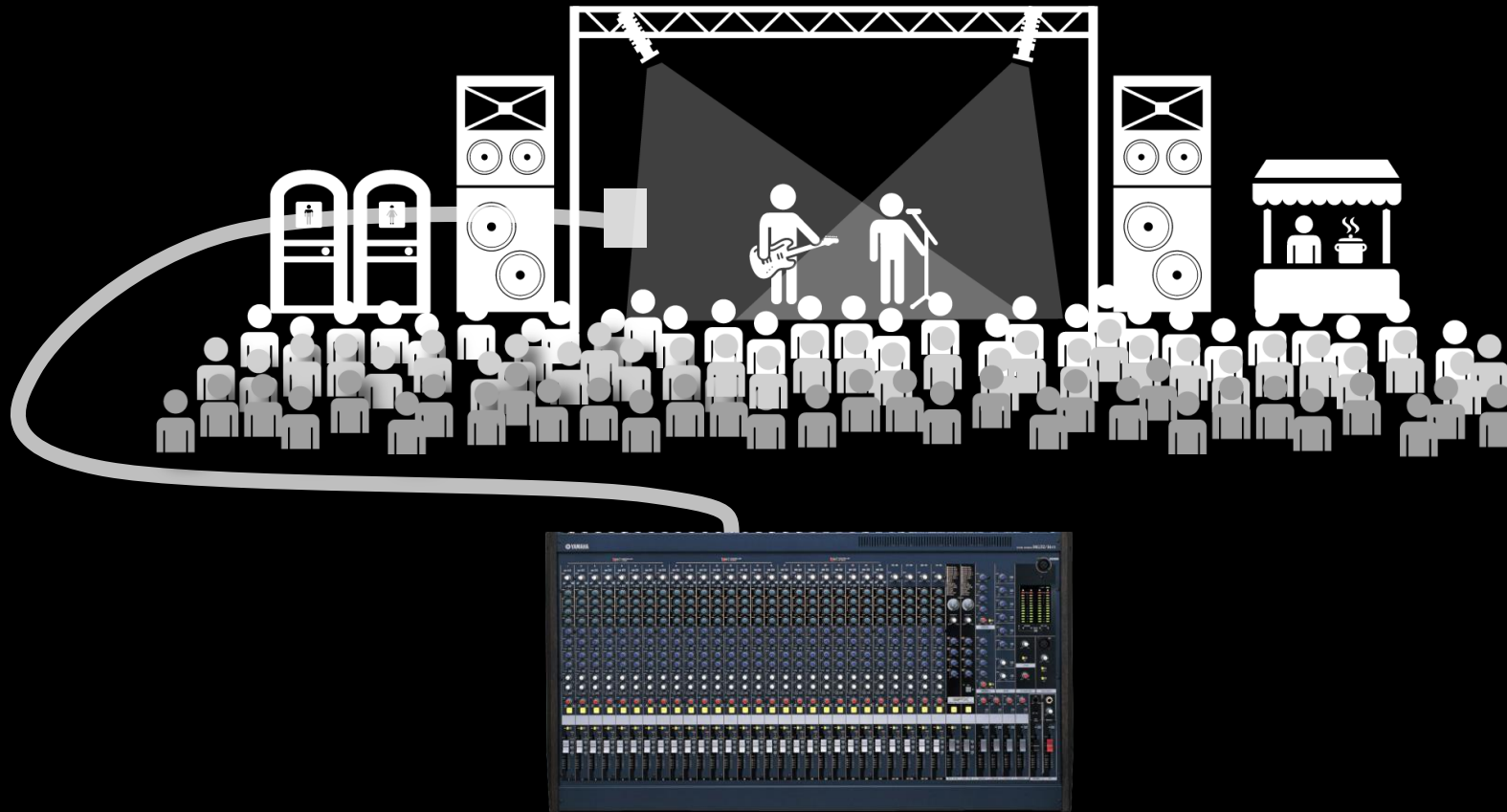

Digital Audio Snakes vs Digital Audio Networks

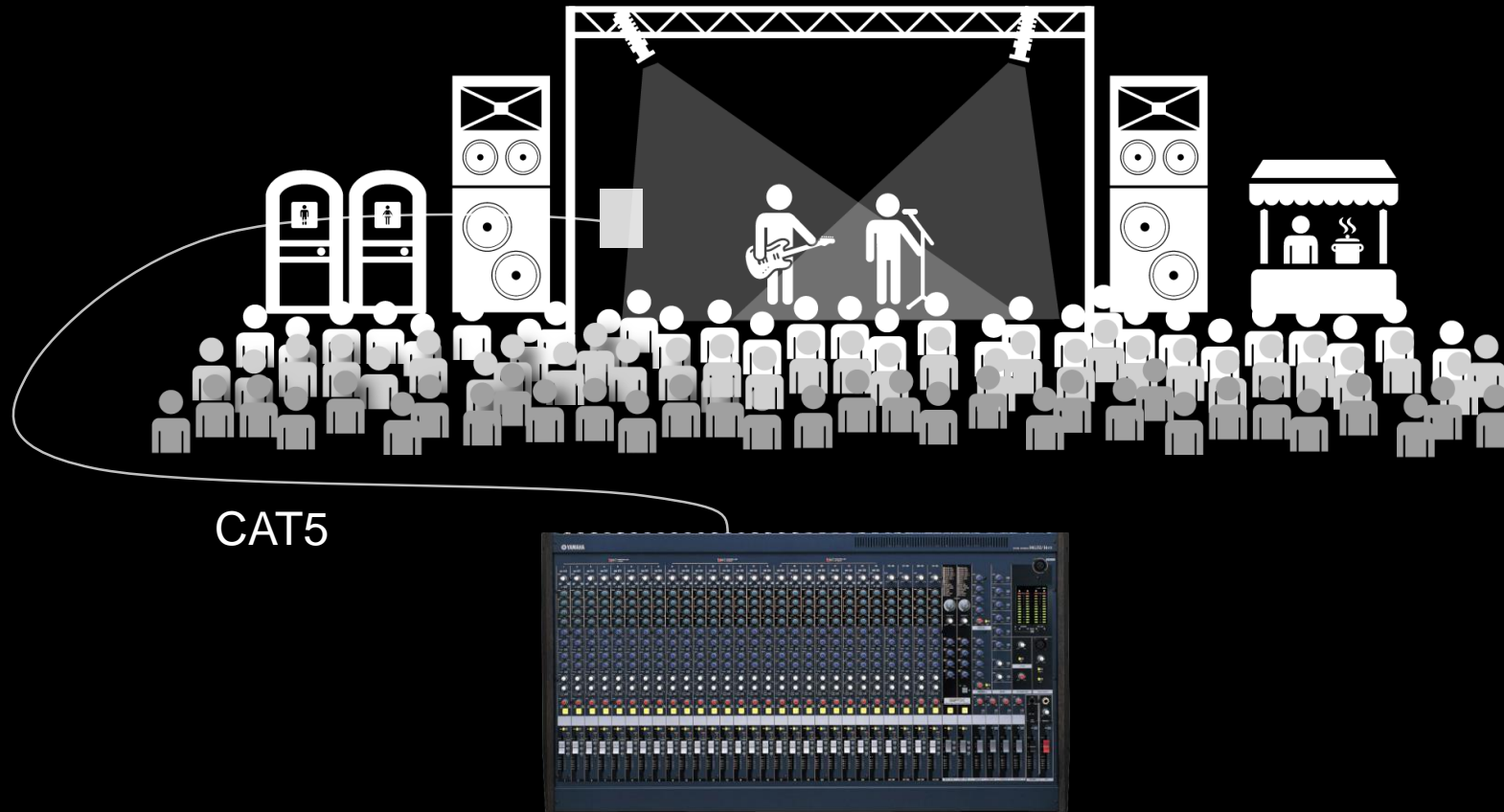

Digital Audio Snakes vs Digital Audio Networks

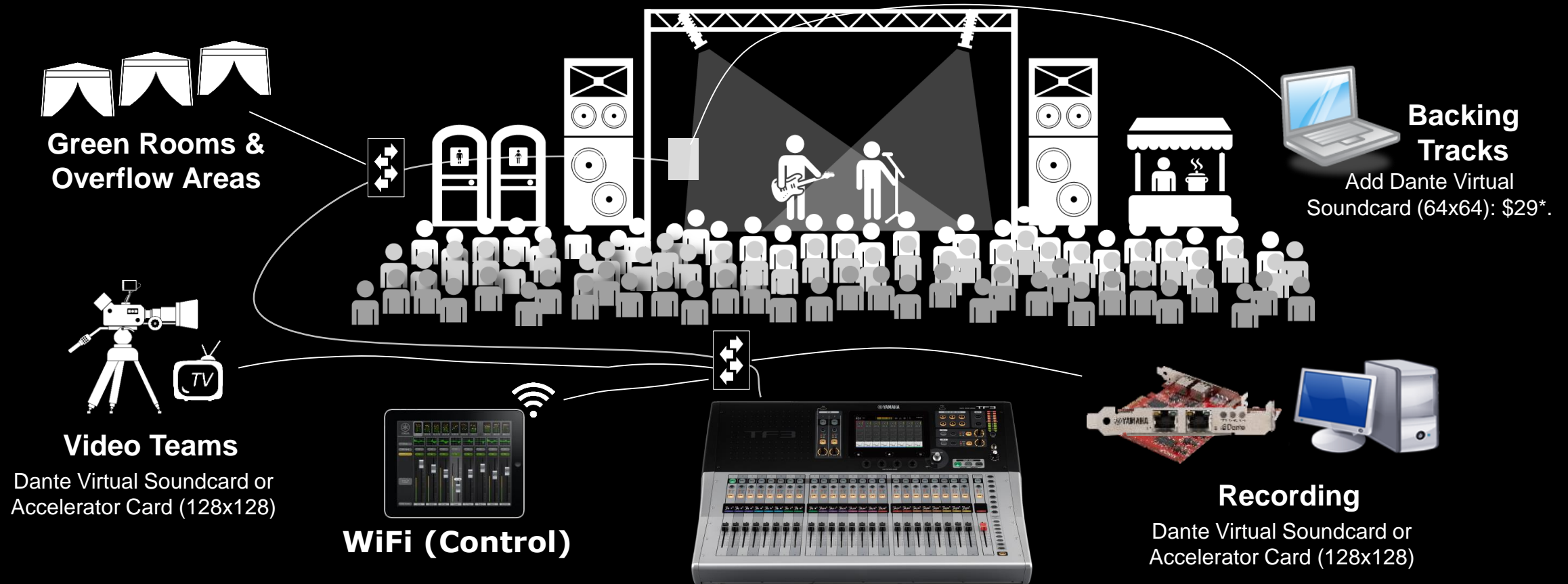

Digital Audio Snakes vs Digital Audio Networks

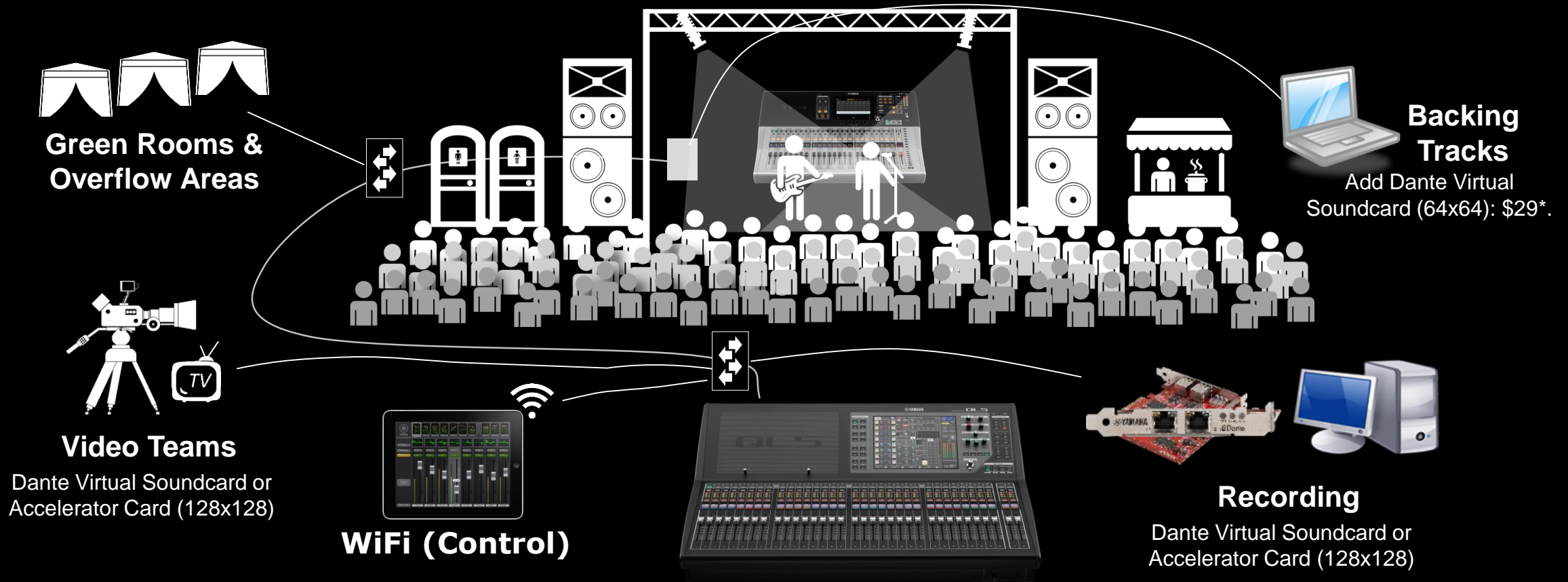

Digital Audio Snakes vs Digital Audio Networks

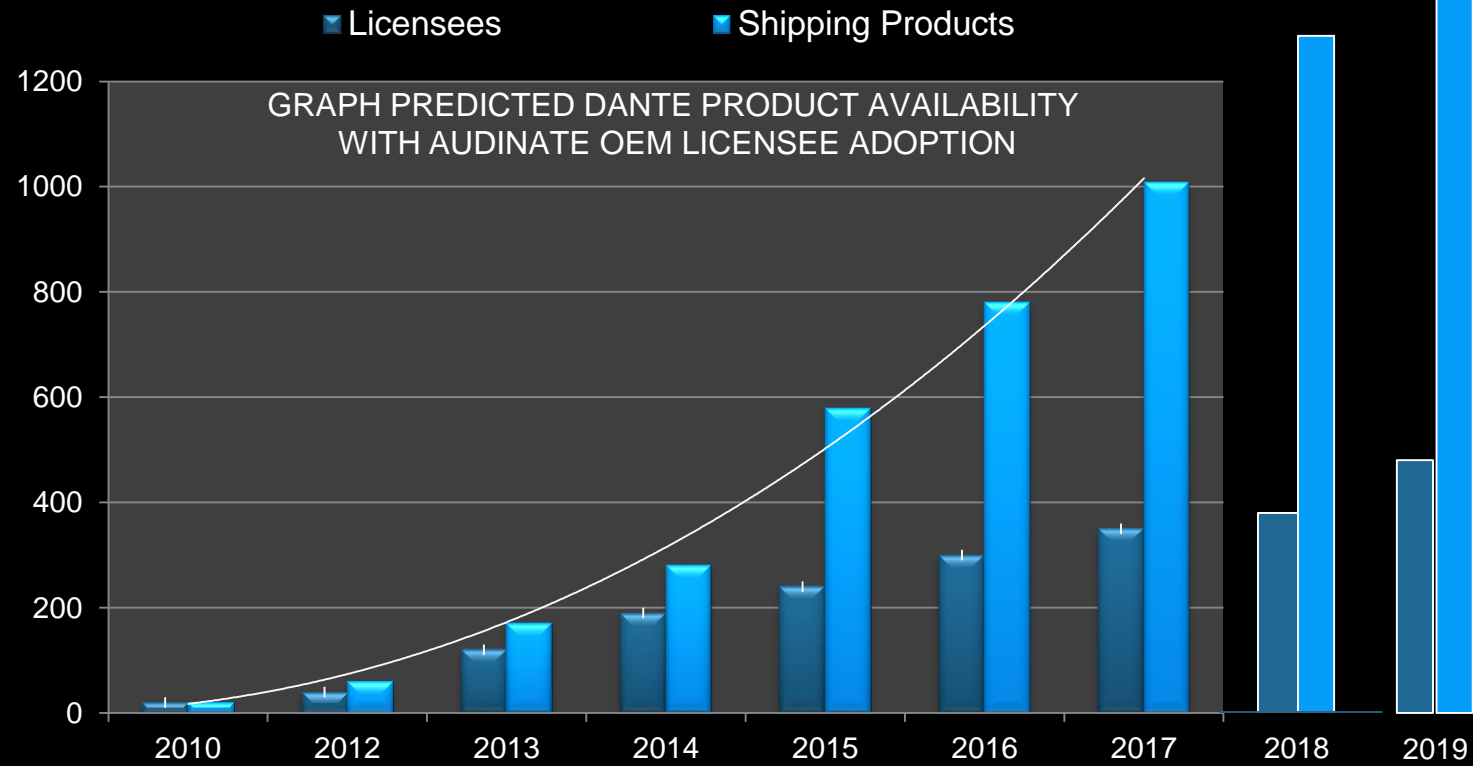

Source: RH Consulting, Audio Networking Survey 2016

Digital Audio Snakes vs Digital Audio Networks

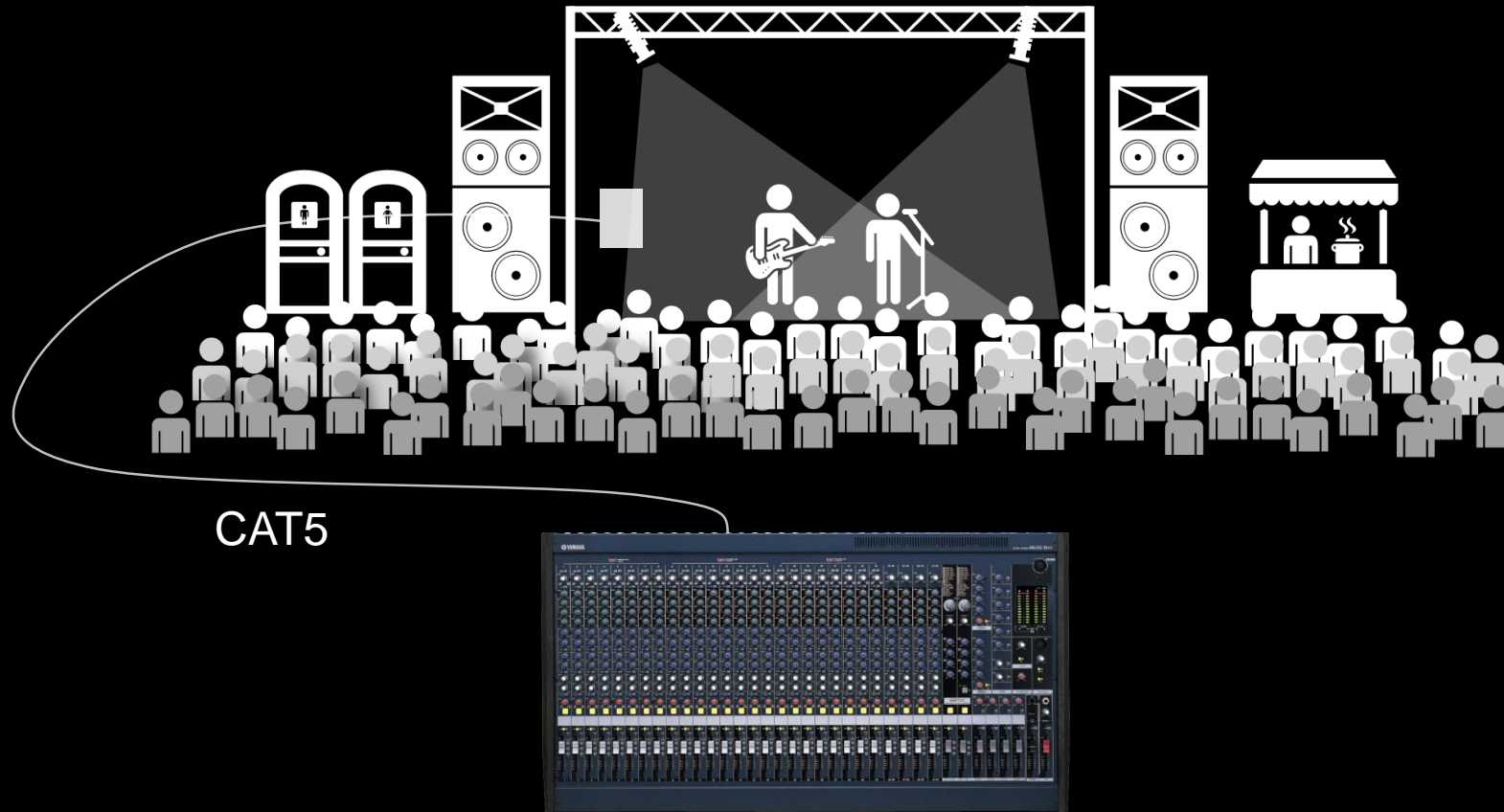

Digital Audio Snakes vs Digital Audio Networks

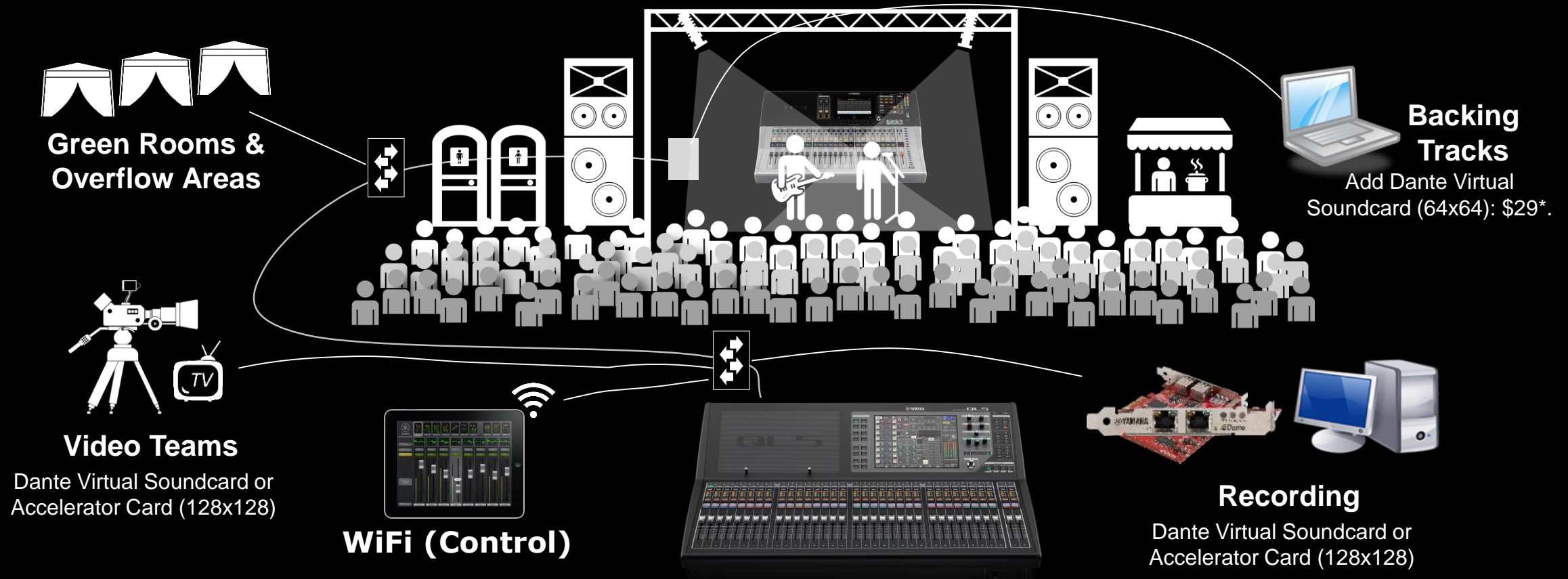

Digital Audio Snakes vs Digital Audio Networks

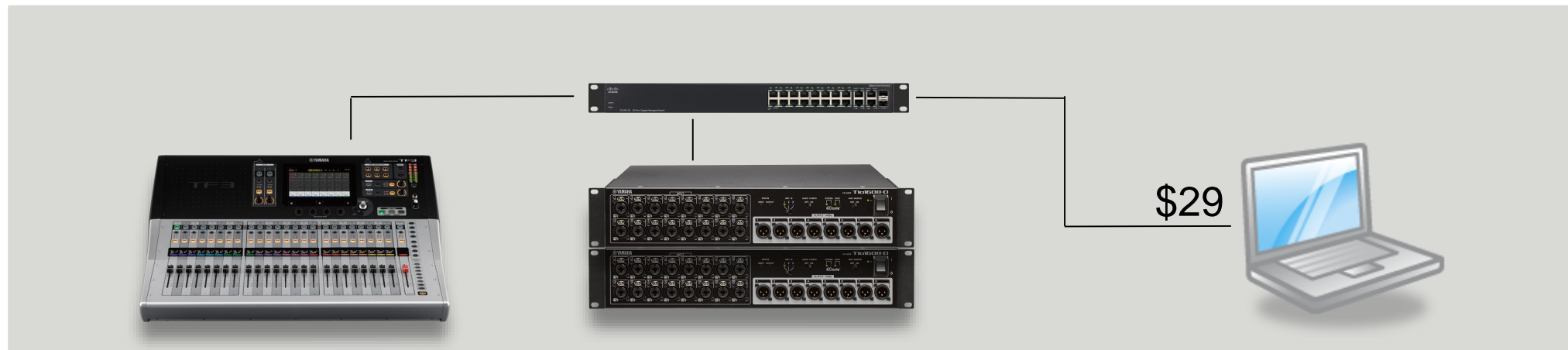
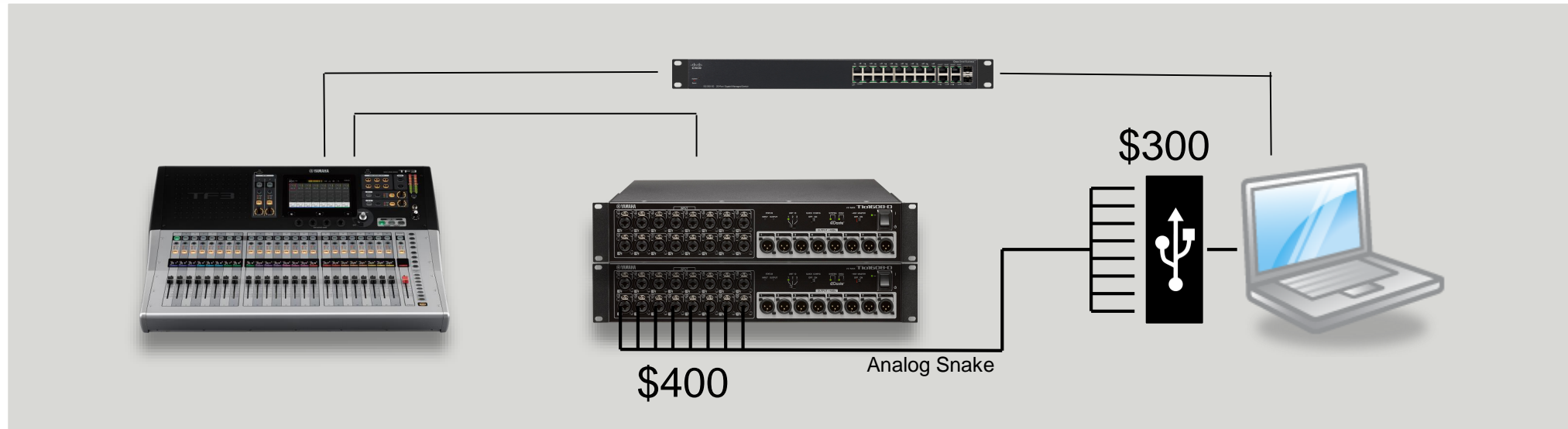



Q: Why do we use Digital Audio?

A: It enables us to do things we couldn't do before.

How Do I Connect Dante Devices?

Dante Ports and Functions



Dante Ports and Functions: Daisy Chain

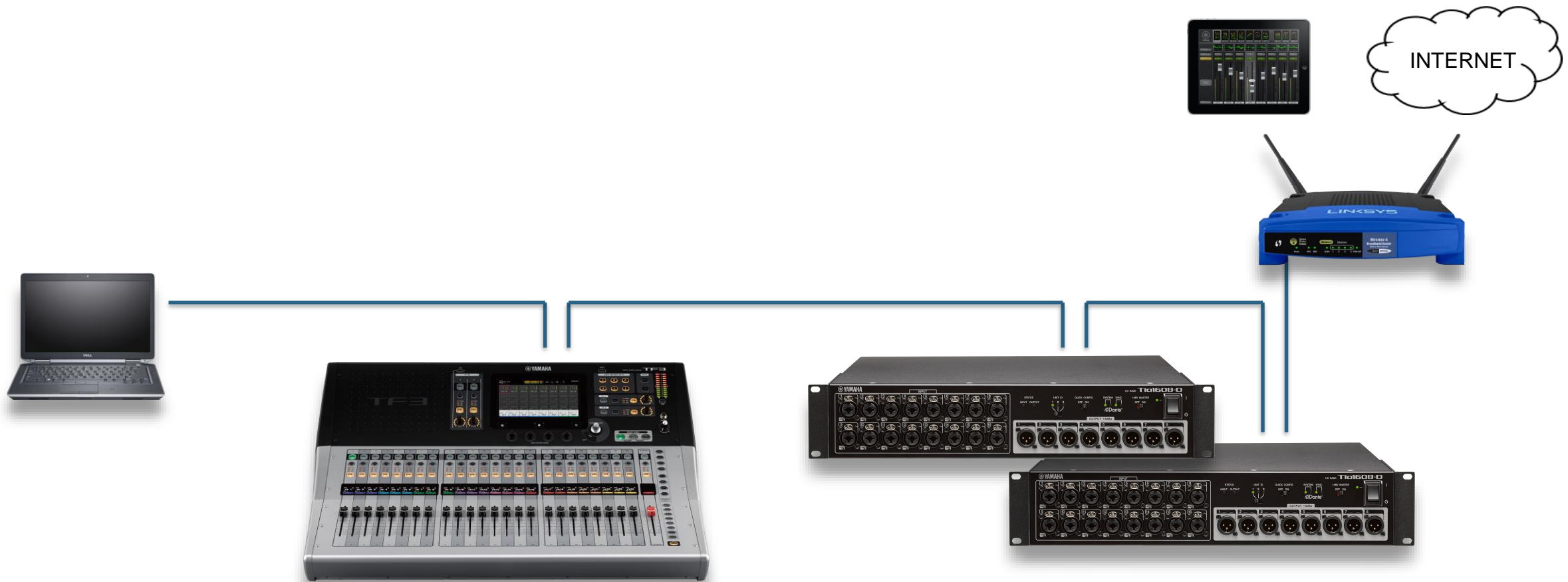

Dante Ports and Functions: Daisy Chain w/ Switches

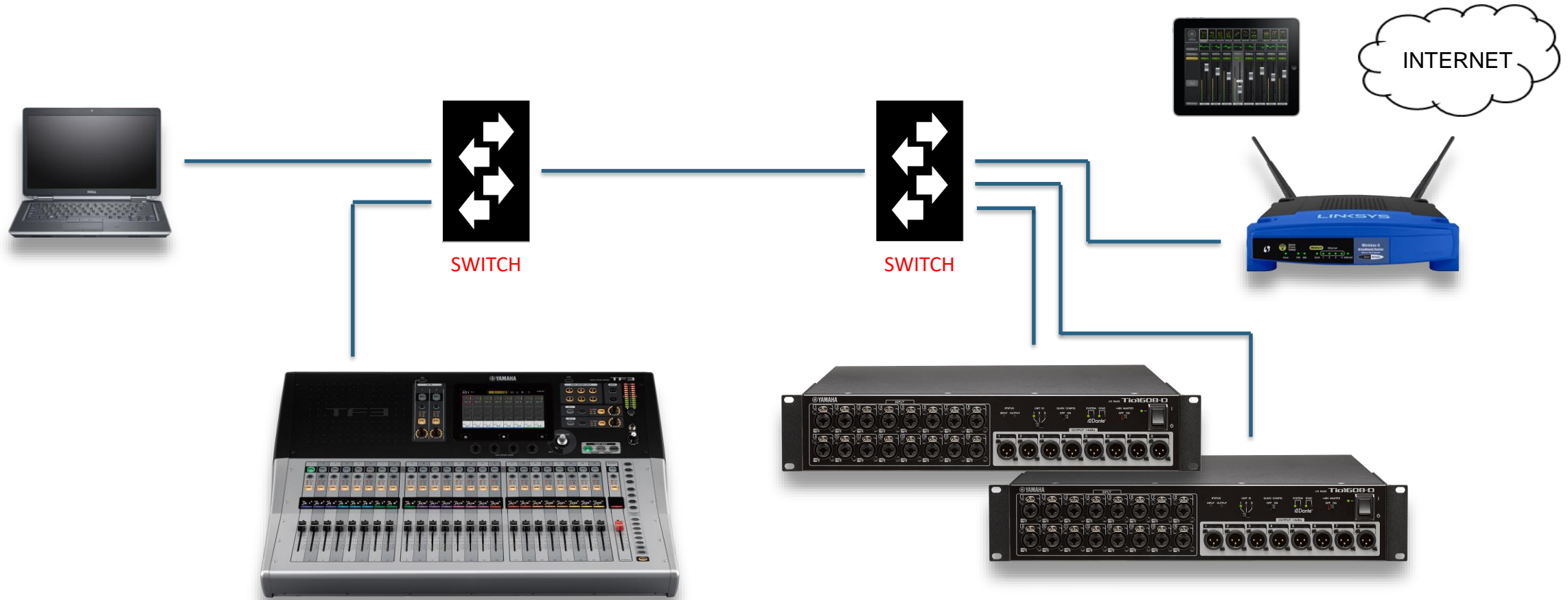

Dante Ports and Functions: Daisy Chain w/ Switches

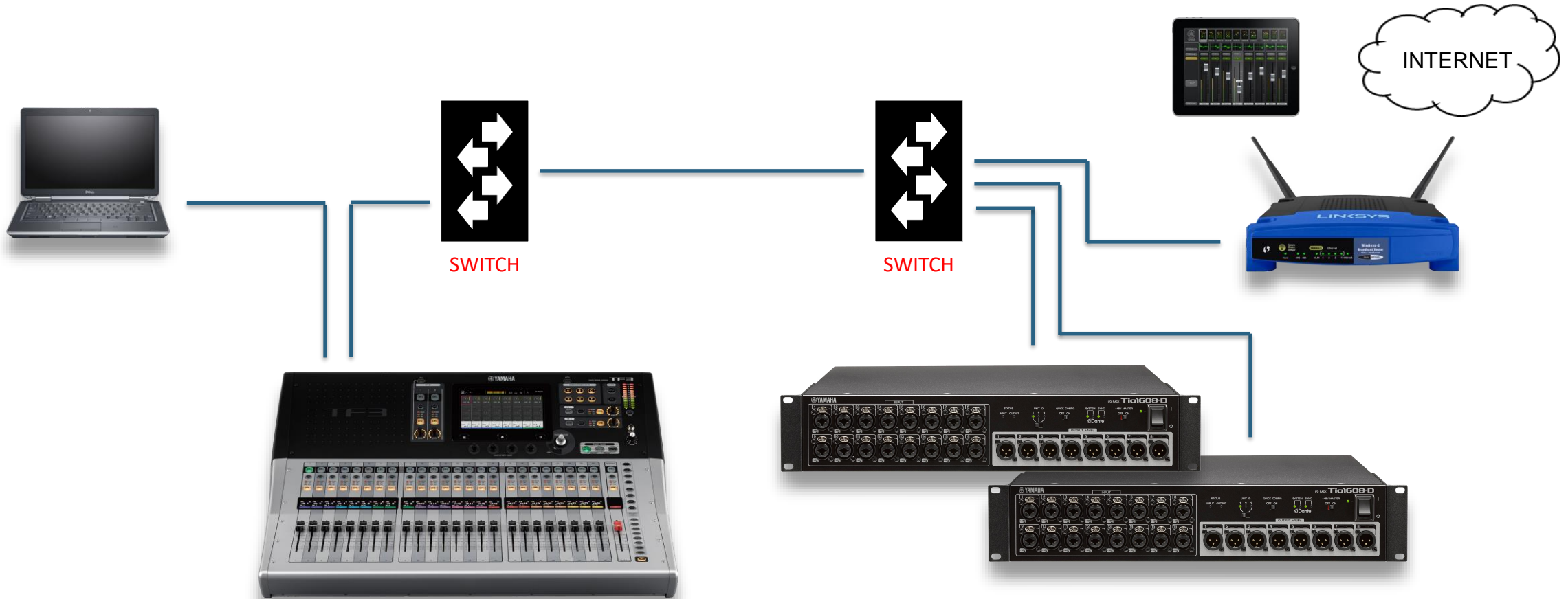

Dante Ports and Functions: Redundant



Redundant Networks – Both Run Full-Time



Redundant Networks – Both Run Full-Time



Manufacturer's Control Port:

Mixers: iPad Control

StageBox: Mic Preamp Settings

DSPs: DSP Programming, Configuration & Control

Wireless Mics: Frequency Coordination

Powered Speakers: Gain, EQ



Manufacturer Control Port

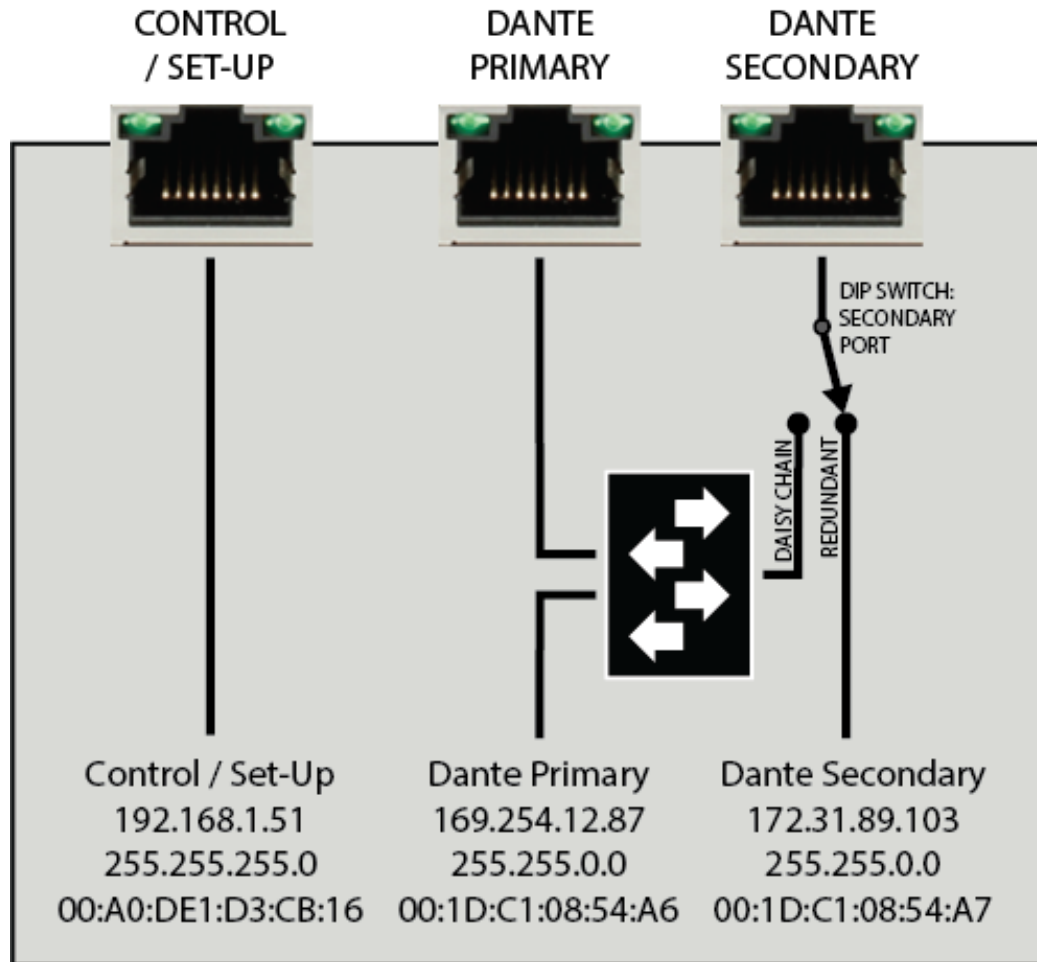

Manufacturer Control Port

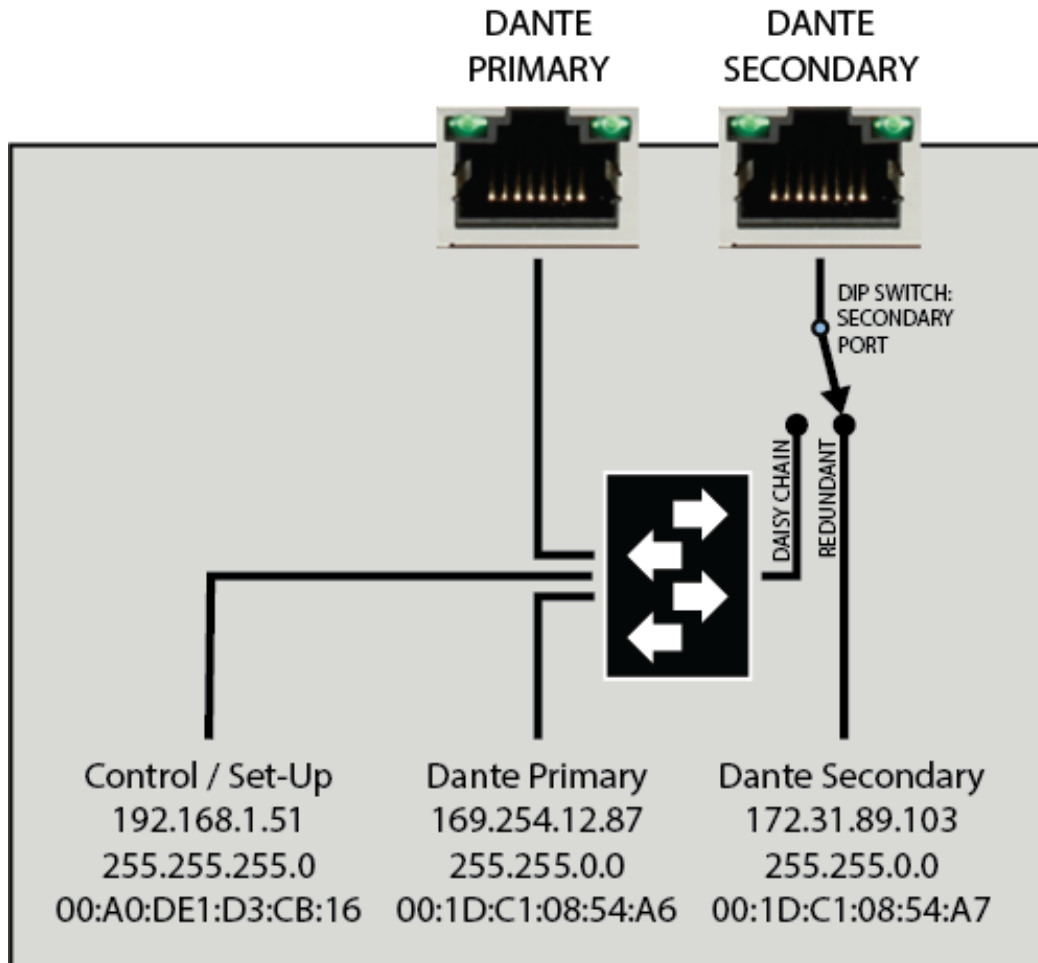

Dante Working Knowledge

(Hands On)



Patrick Killianey



Senior Technical Training Manager
1200 NW Naito Parkway, Suite 630
Portland, OR 97209
patrick.killianey@audinate.com